

For Ordering & Handling

■ Product classification

The following table shows the product classification including the standard and the made-to-order products.

Display	Classification	Concerning delivery
No mark	Standard	Always keep constant stocks. However, it depends on order quantity that we may request for some lead time.
☆	Semi-standard	It depends on the order quantity that we do keep the parts to support the production, 2 weeks lead time for the delivery. However, There is a fluctuation that it depends on the order status. For the details, please contact our sales department.
★	Made to order	It is an order to made products. The delivery (1.5 month) is our standard lead time. However, There is a fluctuation that it depends on the order status. For the details, please contact our sales department.
▲	Ask for details	Concerning lead time, please contact our sales department.

■ Placing an order for accessory parts

- (1) Accessory parts include the standard and optional accessories. The classification is stated on the List of Accessories by Models. The standard accessory parts come with the product. The cost of the optional accessory part is not included in the main body price and is sold separately.
- (2) For placing an order for an accessory part, be sure to specify the part number. The accessory parts do not come with the product at the time of delivery. It is attached separately.
- (3) When purchasing an accessory part only, irrespective of the standard or the optional accessory, it is sold in units of 10 pieces.

■ Placing an order for UL- or CSA-approved product

Even if the products are of UL- or CSA-approved ones, the products in stock do not carry the UL mark of the CSA mark. When placing an order, be sure to specify "With UL/CSA Mark." For the products with the UL mark or the CSA mark, extra costs will be added, excluding A, LP, STE, SLE6, SL10, SLE10, SLE210, SLA215K Series products.

■ How to place an order

When an order is place for the switch and the accessories at the same time, specify the "product name (part number)" and the "part number of accessory." Note, however, that the standard accessories for panel mount (lock nut, locking washer, locking ring, etc.) will be attached, if not specified. For the accessory parts except the lock nut, locking washer and locking ring, be sure to specify the part numbers even if they are the standard accessories (buttons, caps, levers, rockers, for example) since they will not be attached if they are not specified.

■ Packaging style

Delivery in the packaging style of respective series products shall be made for orders for the whole number multiple of the minimum packaging unit of respective series products.

■ Indication of ratings

The ratings described on the catalog show the maximum value under the resistance load. All rated voltage and current values are indicated in "RMS values."

■ Types of load

(1) Resistance load

The resistance load implies the load of a resistive component only where the power factor is 1 ($\cos\phi = 1$). The ratings are indicated in the rated voltage and current under the resistance load.

(2) DC load

For the DC load, being different from the AC load, the arc-length continuation time becomes longer under the same voltage condition. Therefore, it is recommended that the current at 30 V DC should be the same value as the rated current at 125 V AC. Be sure to connect the common terminal to the (-) side.

(3) Lamp load

When the switch is turned on to illuminate a lamp, the rush current 10 to 15 times the steady current flows momentarily, which may cause fusion of contacts. Be sure to choose a switch, considering such transient current.

(4) Induction load

For the induction loads (transformer, solenoid, relay, etc.), peak current flows when the circuit is turned on and an arc is generated due to the reverse voltage when the switch is turned off, which results in much more wear and transition of contacts than the resistance load, making the electrical life shorter. Use the switch at 60% or below of the rated current with the reference power factor of 0.6 ($\cos\phi = 0.6$).

(5) Motor load

With the motor, the striking current three times to eight times the steady current flows at the time of start, which may cause fusion of contacts. Choose the switch by referring to the values shown in Table 1, since the electric current several times the nominal current will flow depending on the types of motor. In addition, to rotate the motor reversely, it should be considered to prevent the synergistic current (starting current + reverse current) by using the ON-OFF-ON type switch.

(6) Capacitor load

For the capacitor load, the charging current of two to 100 times as much will flow when the switch is used for the strobe circuit, welding machine, DC power supply, etc., which may differ according to the capacity of capacitor used. Therefore, be sure to use the switch in the range not exceeding the rated current. In addition, it is recommended to insert a resistor in series and insert the protective circuit, etc. across the switch contacts.

(7) Current capacity according to types of load

LOAD TYPE	MAX. VOLTAGE AND CURRENT
Resistive	Rated Voltage and Current
DC Load	1/4 of Rated Voltage
Lamp Load	1/15 to 1/10 of Rated Current
Inductive	1/10 to 1/3 of Rated Current
Motor Load	1/8 to 1/4 of Rated Current
Capacitor	1/100 to 1/2 of Rated Current

The above-stated values vary according to conditions and should be used just as references.

■ Contact Wear Protection Circuits

For the cases of induction load, etc., it is recommended that CRs, diodes, varistors, etc., should be inserted into the circuit to reduce contact wear due to arc resulting from abnormal voltage/current generated during switch operations.

EXAMPLES OF PROTECTION CIRCUITS

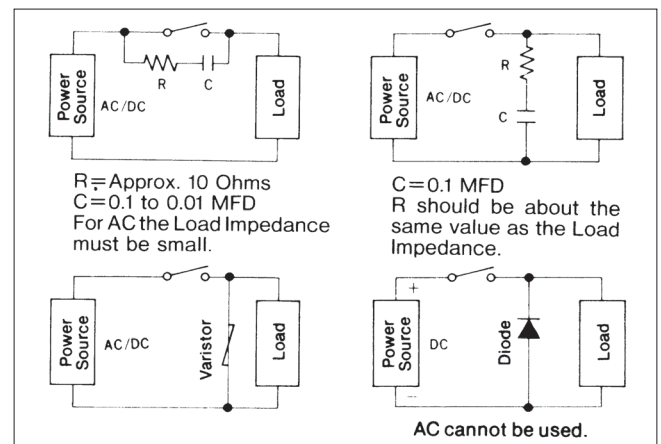
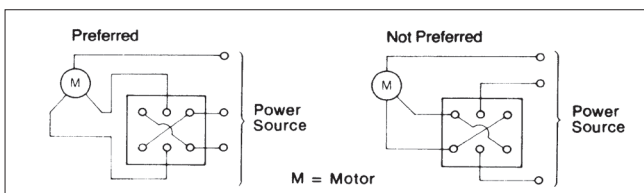

Table 1. JIS C4201 (1959)

MOTOR	TYPE	INRUSH CURRENT
3 Phase Induction	Squirrel Cage	5 to 8 Times Steady State
Single Phase Induction	Spilt Phase Start	6 Times Steady State
	Condenser Start	4 to 5 Times Steady State
	Repulsion Start	3 Times Steady State

When you use the motor in reverse rotation mode, contact us. We will recommend the switch suitable to the performance of each load. Be sure to observe the circuit description shown below.



■ Low-Current (Dry Circuit) Applications

For silver contacts, the contact surfaces are likely to be sulfurized due to aging, peripheral environment, etc., and contacting may become unstable when the switch is used in dry circuits. In addition, due to the similar causes, insulation may be deteriorated due to generation of migration. Therefore, when the switch is used in dry circuits, it is recommended that Fujisoku gold-plated switches should be used.

■ Use Environment

- (1) If the switch is used under the environment where gases (hydrogen sulfide, ammonia gas, etc.) are present, be sure to use the gold-plated switches that offer excellent resistance to corrosion.
- (2) If the switch is used under the environment where water drops, dust, etc. are present, be sure to use the waterproof types (**8F** and **8P** types). The waterproof caps are also available as optional parts.
- (3) When the switch is used under low atmospheric pressure atmosphere, contact arcing is more likely to occur than under normal pressure atmosphere. Carefully consider voltage and current values when selecting the switch.
- (4) When the switch is used under temperatures below -20°C , operation failure due to grease freezing and cracks on molded materials may occur. Under temperatures exceeding $+80^{\circ}\text{C}$, the internal temperature may rise abnormally due to joule heat, thereby causing deterioration in the insulation materials. Be sure to use the switch within the operating temperature range.

Note: Some series products offer the operating temperature range from -40°C to $+85^{\circ}\text{C}$. Be sure to check the specifications of the series products when selecting the switch.

- (5) Operating temperature range
We guarantee the operating temperature range according to the evaluation based on the product specifications and we do not permanently guarantee the use within the temperature range.

■ Storage Environment

- (1) We recommend the following storage environment:
(The independent specifications of each product shall take precedence.)
 - Temperature
Refer to the individual specification drawing or product specification.
 - Humidity
The humidity must be 85% RH or below.
 - Places not suitable for storage
The room where temperature and/or humidity changes severely or condensation occurs. Places around the air supply opening or around the window through which outside air is always taken in. Places where corrosive gases such as the exhaust gas of vehicle or sulfur components may be generated or come in.
 - Others
Do not take the out products unnecessarily before they are used. Make consideration regarding the storage environment of products or parts in process.
- (2) Consider the following storage environment:
 - Blister phenomenon
If the surface-mount type of product is left for a long period of time under the high temperature and high humidity atmosphere before it is mounted, blisters might be formed inside the resin due to the soldering heat. To store the product for a long period of time, take measures to avoid high humidity or reduce absorption of moisture by using silica gel.
 - Discoloration of terminal
To avoid terminal discoloration, pack the product with a plastic bag or the like for storage and avoid storage in high-temperature and high-humidity places or in places where gas atmosphere exists around the places. When the product is delivered with the silica gel, keep the silica gen in the package and store the product in the sealed stage as much as possible.

■ Advice for Using the Switch

- (1) Even for the resistance load, it is general that not only the pure resistance, but also inductive or capacitive components are included. Therefore, for actual use, it is recommended that the switch should be used at 80% of the rated current.
- (2) To extend the service life of the lamp-illuminated switch, the bias current circuit as shown below is recommended.

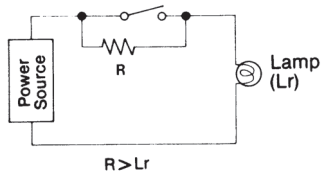

R : Bias Current Resistance
Feed a current small enough to not light the lamp.

- (3) To enhance the contact reliability, the max. current should be kept below the rated value even if 2-, 3- or 4-pole switches are used as single pole switch.

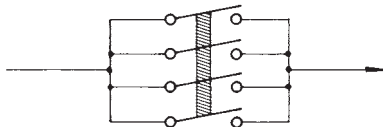

- (4) For the induction circuit or the capacity circuit in which transient current flows during switch operations, measure the transient current value with a synchroscope or the like and use the switch in the range where the transient value does not exceed the rated value.
- (5) For use with the circuit where the operation frequency is very low and the current value is 10 mA or below, use the switch whose contacts are gold-plated.
- (6) In case short-circuiting across poles is concerned, provide an unused pole as shown below.

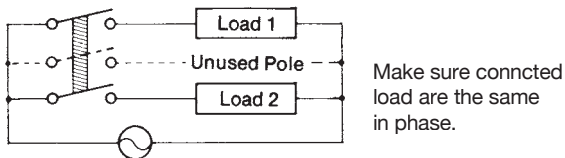

- (7) For an example to easily identify the operation circuit, effectively use color caps or color buttons.
When the switch of PC terminal is used as a soldering terminal, use a thinner lead wire and solder the wire after wrapping it around the terminal.
- (8) The panel sealing capability of the waterproof switch ensures no problem when it is left in water 1 meter deep for 30 minutes. However, do not operate the switch in water.
- (9) When the switch is used for changeover of motor or meter, use the center-off type ON-OFF-ON) switch to prevent dead short-circuit due to switching time lag or adhesion caused by reverse voltage arcing.

■ Operating Frequency of Switch

When the switch is used in the minute electric current range (50 V DC, 0.1 A or below), be sure to operate the switch at least once a month.